

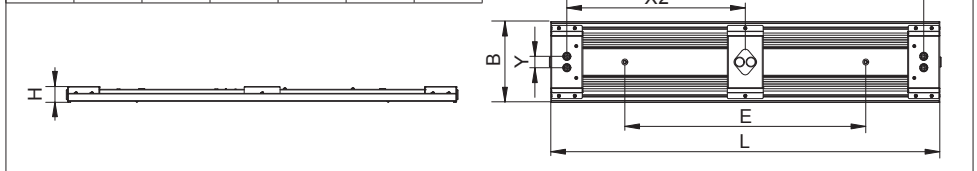

			IP 40		
220-240 V 50-60 Hz			LED	Replaceable control gear by a professional.	
			Replaceable (LED only) light source by a professional.		

L	B	H	E	X1	X2	Y
1735	213	42	1160	1650	825	30



Deckenbefestigung | Ceiling mounting | Fixation au plafond

1. $2x$ ↑ ↻

2. ↑

3. ↻

4. ND, DALI

5. ↓

6. ↻

ND / P

DALI / P

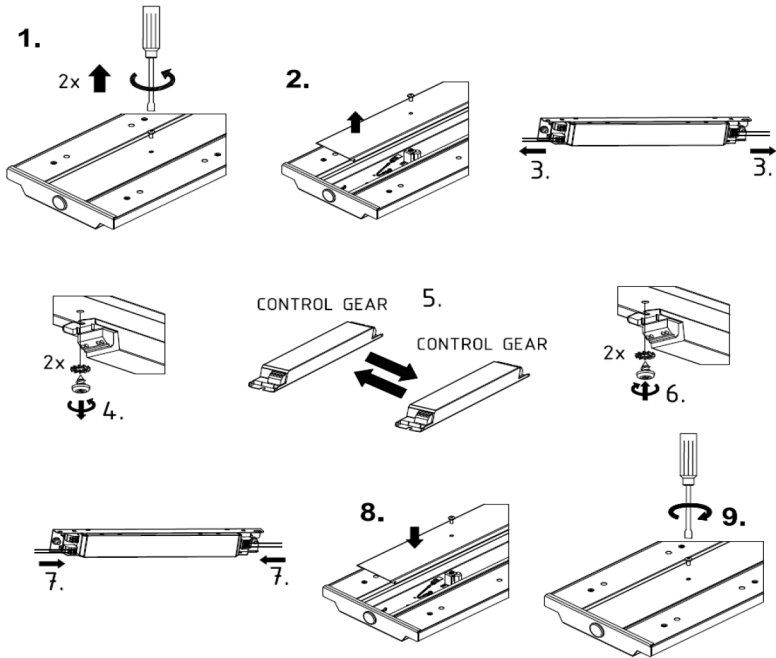

Wand- und Deckenbefestigung | Wall and ceiling mounting | Fixation au mur et au plafond



SALEM FL Wand-/Deckenbefestigung, schwenkbar, 180° (Separat erhältlich.)
 SALEM FL wall/ceiling mounting, swivel, 180° (Sold separately.)
 SALEM FL Fixation mur/plafond, pivotante, 180° (Vendu séparément.)

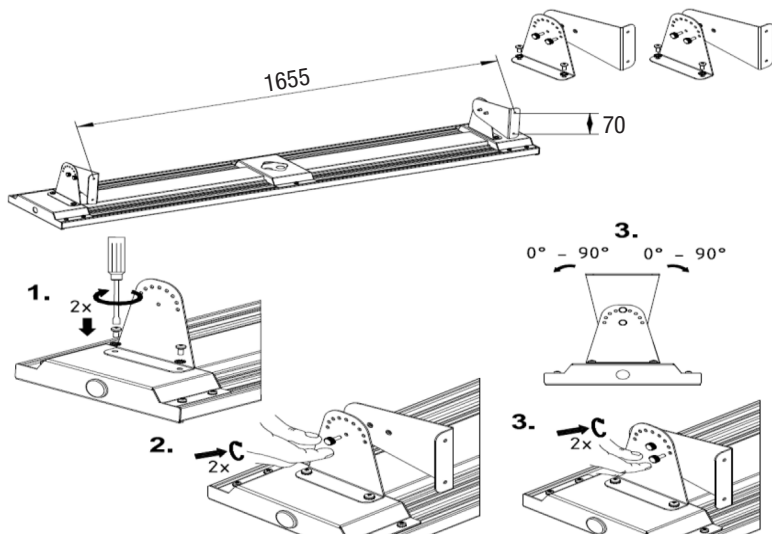

Kettenabhängung | Chain suspension | Suspension par chaîne

